

22/00003/FUL

Units 58 To 69 And 82 To 90

Heming Road, Redditch, B98 0EA

Alterations to roof parapets to accommodate the repair
/ replacement of existing flat roofs

Recommendation: GRANT subject to conditions

Site Location

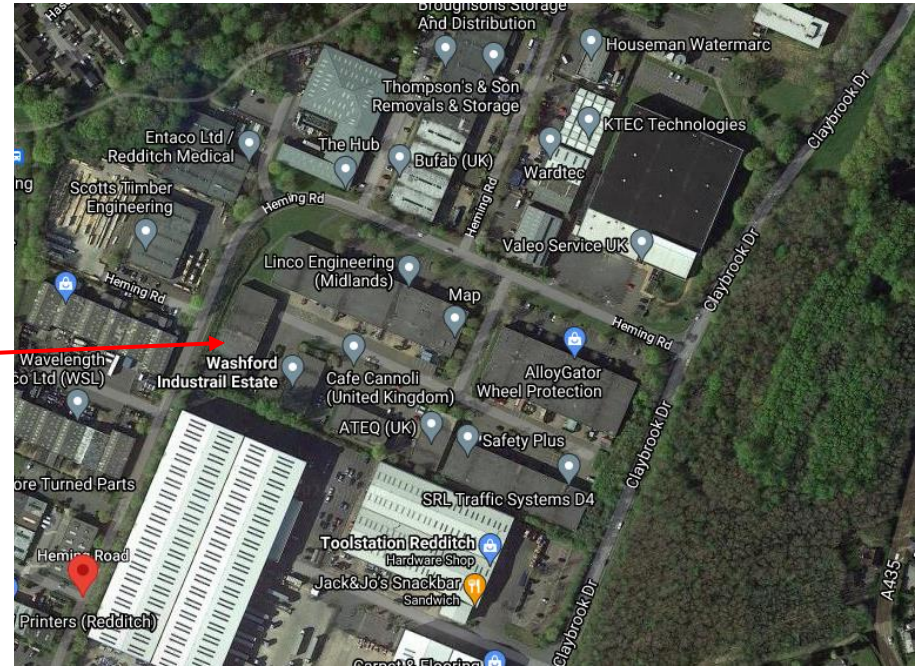
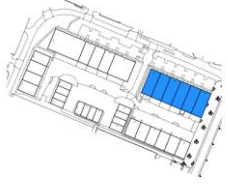

Photo from google (2009) looking at site from the North along Hemming Road

Existing and Proposed Elevations Units 58-63



0 1 2 3 4 5m
Scale - 1:100

Existing

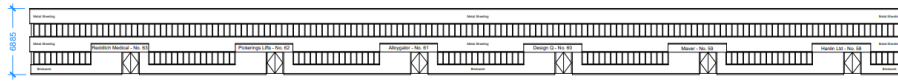

Front Elevation - Units 58-63

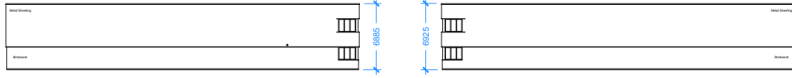

Left Hand Elevation - Units 58-63

Right Hand Elevation - Units 58-63

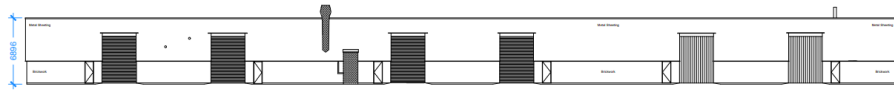

Rear Elevation - Units 58-63

Proposed

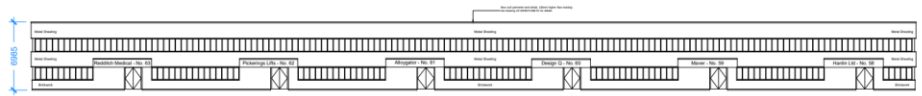

Front Elevation - Units 58-63

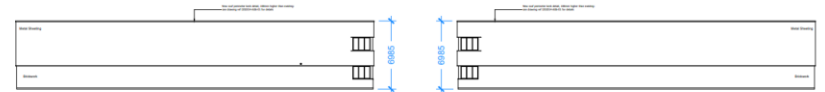

Left Hand Elevation - Units 58-63

Right Hand Elevation - Units 58-63

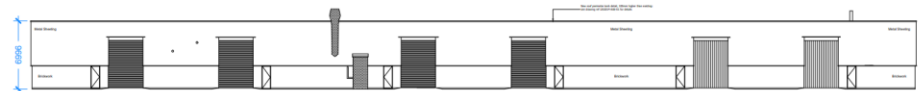

Existing and Proposed Elevations Units 64-69

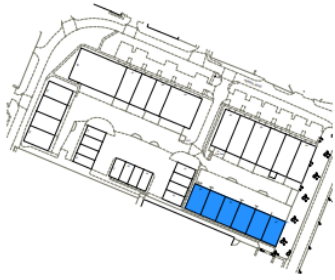

0 1 2 3 4 5m
Scale - 1:100

Existing

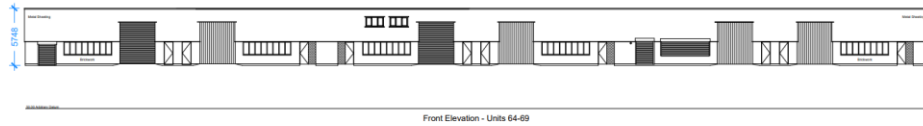

Proposed

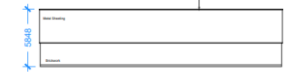
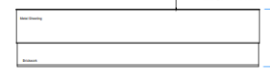
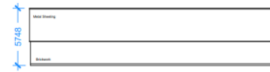
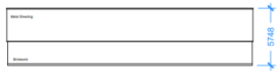
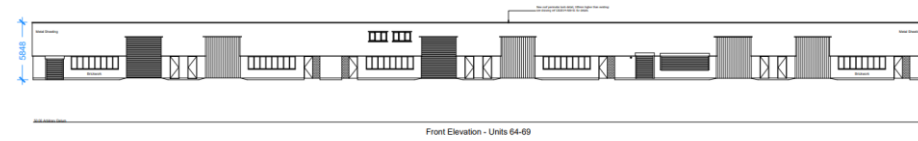

Existing and Proposed Elevations Units 82-85

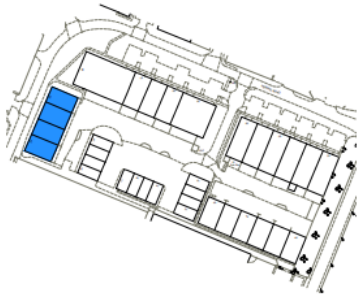

0 1 2 3 4 5m
Scale - 1:100

Existing

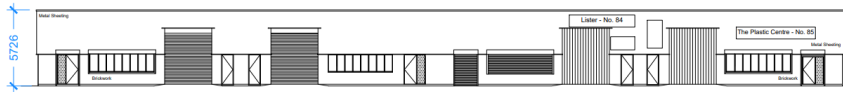

Front Elevation - Units 82-85

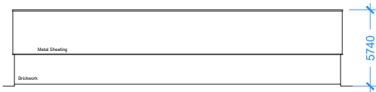

Left Hand Elevation - Units 82-85

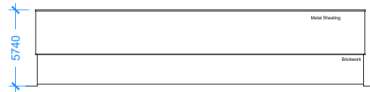

Right Hand Elevation - Units 82-85

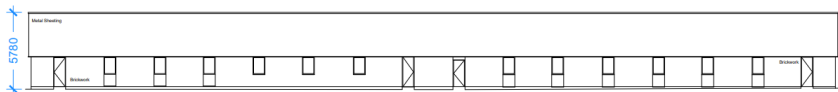

Rear Elevation - Units 82-85

Proposed

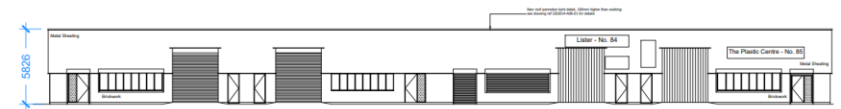

Front Elevation - Units 82-85



Left Hand Elevation - Units 82-85



Right Hand Elevation - Units 82-85



Rear Elevation - Units 82-85

Existing and Proposed Elevations Units 86-90

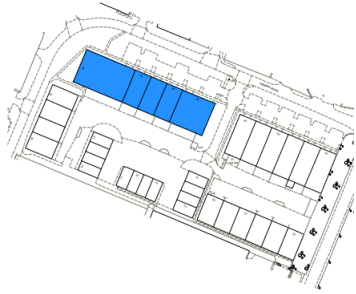

0 2 4 6 8 10m
Scale - 1:200

Existing

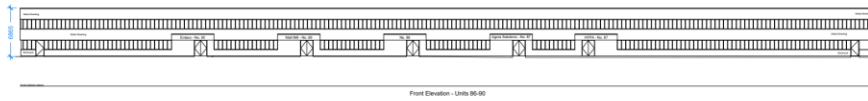

Front Elevation - Units 86-90

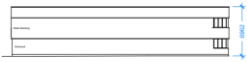

Left Hand Elevation - Units 86-90

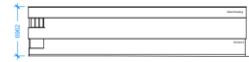

Right Hand Elevation - Units 86-90

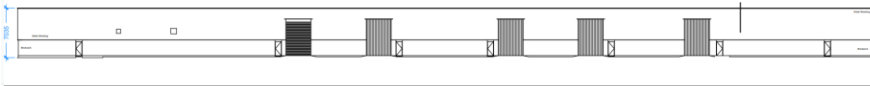

Rear Elevation - Units 86-90

Proposed

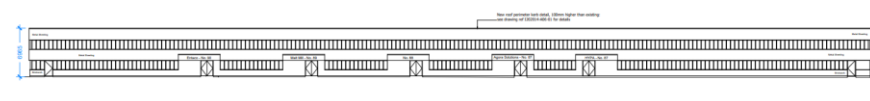

Front Elevation - Units 86-90



Left Hand Elevation - Units 86-90



Right Hand Elevation - Units 86-90

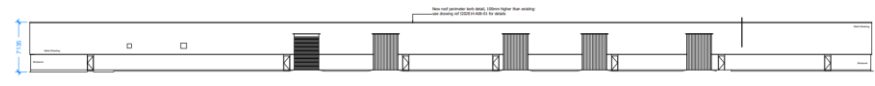

Rear Elevation - Units 86-90

Proposed Roof Kerb Detail

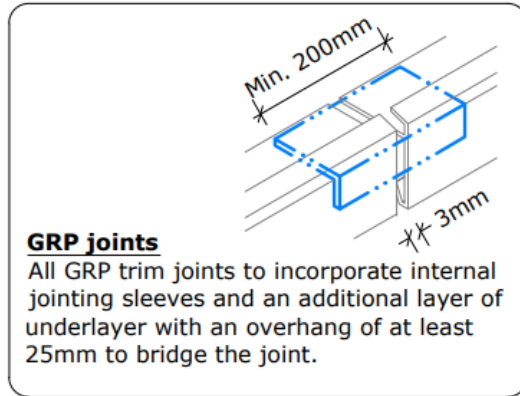

Alternative Details

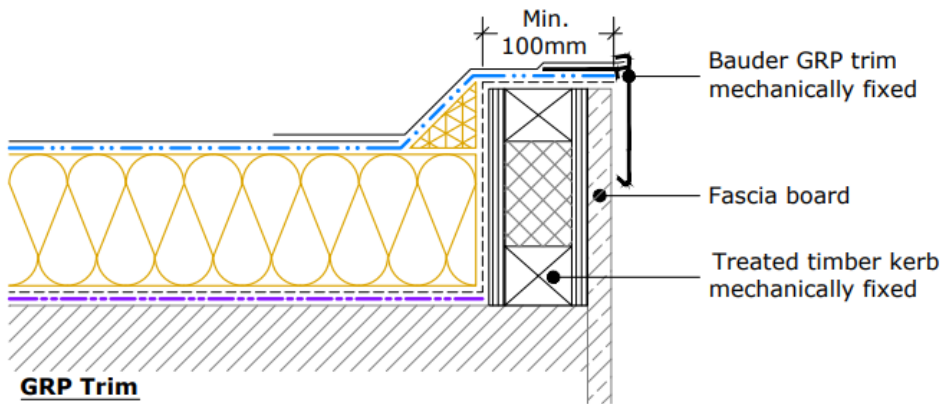
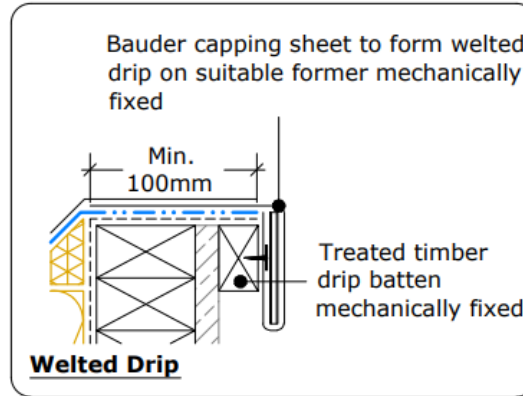

Key

- Bauder Capping Sheet (For all Green Roof details use Bauder Root Resistant Cap Sheet)
- - - - - Bauder Underlayer
- ▨ Bauder Insulation
- - - - - Bauder Vapour Control Layer (Use Bauder Self Adhered Vapour Control Layer on Combustible Substrates)
- Bauder Random Nailed Layer used on TIMBER BOARDED DECKS ONLY
- //// Deck / Substrate

Site Photos

Photo taken from google looking South from Hemming Road towards units 58-63 and Claybrook Drive



Photo taken from google looking east within courtyard area towards rear of unit 58-63 and front of units 64-69

Photo taken from google looking west within courtyard area towards rear of unit 86-90 and front of units 82- 85

